

The Micromag HP/80 follows on from the standard Micromag and has all of the same incredible benefits. This unit was developed to suit high pressure through spindle coolant applications, where the smallest of particles can damage seals, spindles and even the efficiency of the cutting tool.

Micromag HP/80 can be installed anywhere in the fluid delivery system and will ensure that even sub micron magnetic and paramagnetic particles are removed before they can cause any expensive damage.

For further information relating to the benefits and operation please refer to the supplied standard Micromag brochure.

### Cleaning

Using the supplied cleaning tool, a fully contaminated core can be cleaned in under 30 seconds! Leaving you with only the metallic particles, which can be easily disposed of, no dirty cartridges!



### Suitable Products

Neat & soluble oils.

### Installation Location

Pre or post pump, delivery line, spindle feed or pre membrane cartridge.

### Benefits

- High pressure rated
- Sub micron filtration
- Large holding capacity
- High intensity Rare Earth magnetic material
- Full Stainless Steel construction
- Suitable for all machining applications
- Environmentally ethical
- No consumables

### Category

High Pressure.



# Technical Data:-

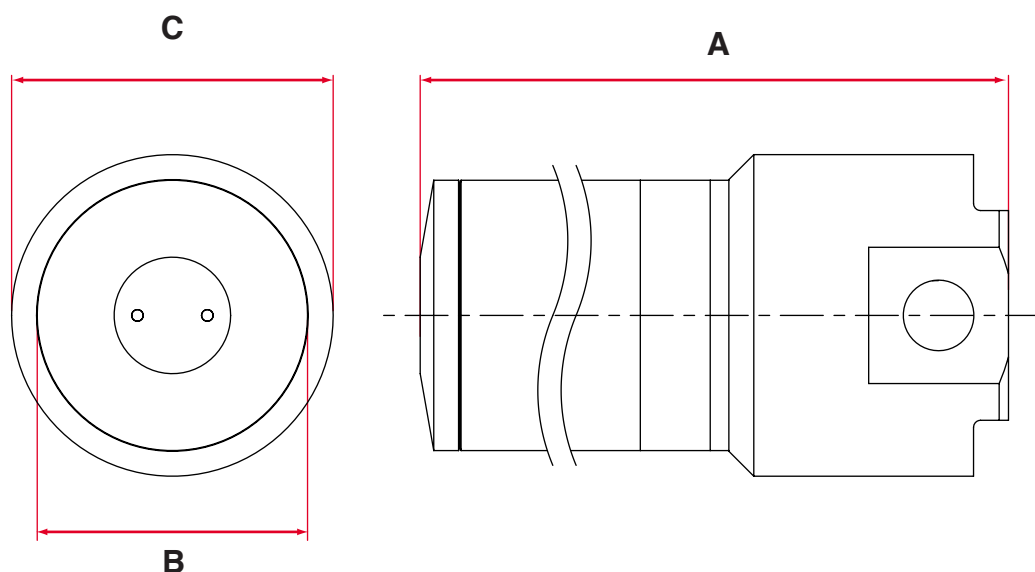

Product number	Flow rate Gallons/min	Contamination capacity lbs	Max. operating pressure psi	Connection NPT (in)	Temperature range F	Construction	Dimensions inches		
							A	B	C
MM5/HP/80 NPT	18	2.2	1160	1	32 – 284	Full stainless steel construction	9.7	4.6	4.9
MM10/HP/80 NPT	26	4.4	1160	1	32 – 284		14.3	4.6	4.9
MM20/HP/80 NPT	40	8.8	1160	1½	32 – 284		24.6	4.6	4.9

## Performance

<b>Maximum Pressure</b>	1160psi
<b>Magnetic Performance:</b>	High Intensity
<b>Circuit Design:</b>	Open
<b>Magnetic Material:</b>	Rare Earth Neodymium Iron Boron
<b>Magnet Grade:</b>	N45 – Inspected & confirmed via hystergaph prior to use
<b>Temperature:</b>	32-284 F

## Materials:-

<b>Housing:</b>	316 Grade Stainless Steel
<b>Lid:</b>	316 Grade Stainless Steel
<b>Tube:</b>	316 Grade Stainless Steel – Aerospace Quality

If you have any more questions, require technical assistance or would like a quotation, please contact us.

[www.eclipsetoolsinc.com](http://www.eclipsetoolsinc.com)

### Eclipse Tools North America Inc.

442 Millen Road, Unit #9, Stoney Creek, Ontario, L8E 6H2, Canada

T 1-800-260-2124 F 1-800-260-1410

sales@eclipsetoolsinc.com www.eclipsetoolsinc.com

While every effort has been made to ensure the accuracy of the information in this publication please note that specifications may change without notice.



FM31278