

FIRETRACE[®]

POWER TO INNOVATE. FLEXIBILITY TO ADAPT.

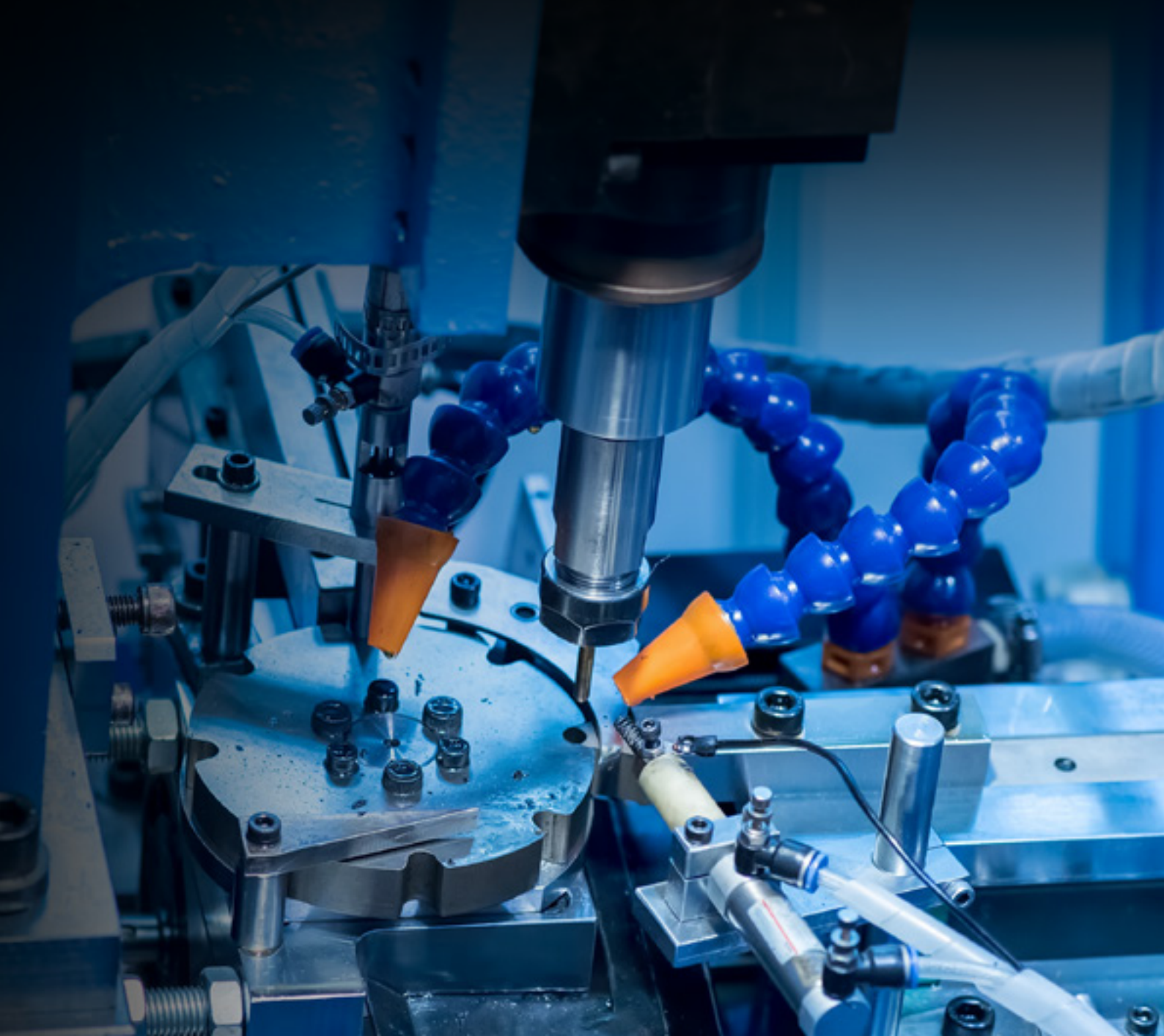

CNC & EDM MACHINING CENTERS

Fire Protection Solutions

FIRETRACE, THE PROVEN CHOICE FOR MACHINING CENTER FIRE PROTECTION

THE PROBLEM

A fire in a CNC or EDM machine can occur in an instant without warning

A hot metal chip, a tool crash, or even a spark of static electricity can ignite the petroleum-based metalworking fluids used in many of these machines. The fire risk increases when a machine is run lights-out or unattended.

Oil-based machine fires produce high heat and dense black smoke that can be difficult or impossible to fight with handheld fire extinguishers. If the CNC machine is fitted with a ducted mist collector, a fire has the potential to spread to the building's structure, where it may grow to the point where it can threaten lives and property.

Should the building's sprinkler system activate in response to a fire, the costs incurred from water damage can exceed the costs incurred from the fire itself; and indirect expenses, such as business interruption, missed deadlines, and lost customers, can be many times again as costly.

THE FIRETRACE SOLUTION

Firetrace offers a unique solution for automatically protecting CNC and EDM machines against the risk of fire. The Firetrace system utilizes flexible red detection tubing that is routed throughout the fire risk area inside the machine. The tubing is pressurized and is designed to burst when exposed to a fire's radiant heat, which triggers the release of the fire extinguishing agent.

Because a Firetrace system detects and suppresses a fire inside the machine – right at the source of a growing fire! – it reacts many times faster than traditional fire suppression systems. And every second saved helps reduce machine repair costs and revenue losses due to unscheduled downtime.

Firetrace CNC and EDM systems utilize gaseous “clean” fire extinguishing agents that are safe to use in occupied areas. Clean agents leave no residue and require no clean up, so downtime is kept at a minimum. Clean agents are fast, effective, eco-friendly and will not harm machines or contaminate expensive machine oils.

FIRETRACE ADVANTAGES

-  – Highly reliable in harsh environments – tolerant of dirt, debris and temperature extremes
-  – Requires no electricity offering uninterrupted service 24/7
-  – Sounds alarm and can send an alert to your monitoring system
-  – Eliminates concern for false alarm or false discharge
-  – Provides immediate detection and delivery
-  – Allows for inexpensive installation, maintenance and recharge



HOW IT WORKS

Firetrace has a system that is right for you. Firetrace offers a variety of pre-engineered systems designed to protect virtually any CNC or EDM machine.



DIRECT RELEASE SYSTEMS

In Direct release systems, the tubing nearest the hottest point of the fire ruptures, forming an effective discharge “nozzle.” The agent contained in the cylinder is then released in the immediate proximity of the fire.



INDIRECT RELEASE SYSTEMS

With an Indirect release system, the Firetrace tubing is used only for detection. When a fire causes the tubing to burst, a valve opens and the suppressant is discharged via a traditional distribution network and fixed nozzles.

FIRETRACE DETECTION TUBING

Firetrace Detection Tubing is ideal for fast, reliable detection of heat and flame even in the toughest applications.



CNC CUTTING, MILLING, TURNING AND GRINDING MACHINES

For CNC applications a Firetrace Indirect Low Pressure (ILP) Novec 1230 or FM-200 system is usually recommended. An Indirect High Pressure (IHP) CO₂ system is also available for machines with very large work areas.

The red detection tubing is routed throughout the work area inside the machine which greatly improves reaction/detection time. The fire suppressing agent is delivered via a pipe and nozzle network to suppress a fire quickly, thus reducing the potential for machine damage.

DIE SINKING EDM (ELECTRICAL DISCHARGE MACHINES)

For EDM applications a Firetrace Indirect High Pressure (IHP) CO₂ system is usually recommended.

The red Firetrace Detection Tubing is routed around the base of the ram just above the typical operating oil level, providing 360 degrees of fire detection and suppression. An optional manual release is an available option.

Large nozzles installed well above the oil surface on both sides of the ram deliver a high volume of CO₂ to extinguish the fire. The CO₂ is delivered as a gentle mist to keep the burning oil from splashing, which would spread rather than suppress the fire.

- Firetrace Detection Tubing
- Discharge Piping
- Discharge Nozzle
- Manual Release

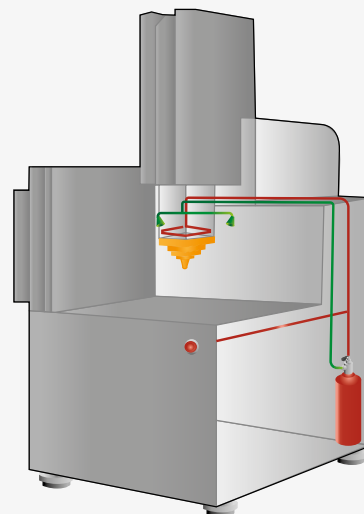
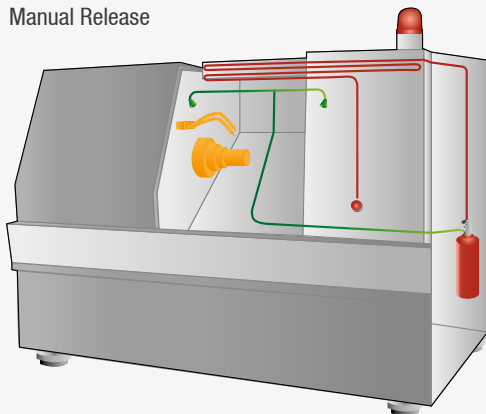

FIRETRACE INDIRECT SYSTEMS ARE AVAILABLE WITH AN OPTIONAL MANUAL RELEASE, ENABLING AN OPERATOR TO ACTIVATE THE SYSTEM AT THE FIRST SIGN OF TROUBLE.

FIRETRACE®

POWER TO INNOVATE. FLEXIBILITY TO ADAPT.

OVER 500 AUTHORIZED FIRETRACE DISTRIBUTORS WORLDWIDE

Providing hazard analysis, quotations, installations, service and support on Firetrace systems, to reliably and effectively protect your assets.

From the adaptable pre-engineered systems using the world-renowned Firetrace Detection Tube to protect critical equipment and enclosures to the innovative new E4 Engineered Systems providing a new level of flexibility in system design, Firetrace leads the world in special hazard protection.

Airports

IT Infrastructure

Mass Transit

Ports and Intermodal Facilities

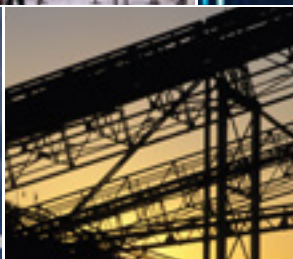

Mining

Military

Oil & Gas

Wind Energy

Pharmaceuticals

A HALMA COMPANY

www.firetrace.com

Firetrace currently has more than 20 international approvals and listings, including UL, CE, FM, ULC & ISO9001. Approvals and listings vary by system type and agent.



FIRETRACE INTERNATIONAL - WORLD HEADQUARTERS
8435 N. 90th St., Suite 2, Scottsdale, AZ 85258 USA
+1 888 607 1218 (USA & Canada toll free)
+1 480 607 1218 • info@firetrace.com

FIRETRACE USA LLC - MIDDLE EAST BRANCH
Office 2117, Building 7WB, Dubai Airport Freezone
(DAFZA), Dubai, United Arab Emirates
+971 56 7599490 • info@firetrace.com

FIRETRACE INTERNATIONAL LTD - EMEA OFFICE
Unit 11, IO Centre, Salbrook Road, Salfords,
Surrey, RH1 5DY, UK
+44 (0) 1293 780 390 • emea@firetrace.com