



AIRHAWK

CARTRIDGE DUST COLLECTORS

The AirHawk Series of Cartridge Dust Collectors from DiversiTech features an innovative, modular design that effectively eliminates dust, smoke and other airborne contaminants from your work environment. Its durable, heavy-duty powder-coated steel construction can withstand continuous operation industrial applications.

The AirHawk's vertical filter design allows the powerful, reverse pulse cleaning system to separate dust from the filters while preventing dust re-entrainment with baffles below, resulting in a cost-effective filter system to operate and maintain. Each filter cartridge is pulse-cleaned individually with a powerful turbo-nozzle, which ensures the maximum amount of material is blown off each filter.

Features:

- Vertical Cartridge filters (Dust is blown off the filter instead of accumulating on the top surface)
- Standard open-pleat Nanotech MERV 15 nanofiber filters
- Non re-entrainment baffles
- Automatic reverse pulse cartridge cleaning system
- Hopper and floor stand or low-profile dust drawer configurations
- Heavy Duty 10-gauge main frame construction with 12-gauge steel panels

Optional Accessories:

- HEPA after-filter
- Silencer
- Dust drawer
- Spun-bond polyester filters
- Abort and Blowback damper
- Explosion vent
- Spark Arrestor
- Catwalk platform and ladder
- Fire detection and suppression system
- Variable Frequency Drive





Air Hawk Advantages

- Modular for unlimited number of filters
- Continuous operation on line and off line reverse pulse
- Each filter is pulsed separately which reduces internal static pressure extending filter life and overall dust collector performance
- Shipped in modules to reduce freight costs
- Many different accessories available to meet NFPA and OSHA guidelines

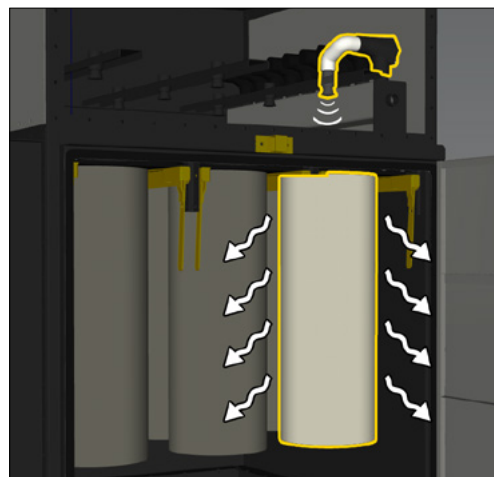

Direct - A - Flow™ Inlet

- Inlet baffle separates larger dust particulates before they reach the filters by directing the dust into the hopper or drawer
- Prevents large particulates from directly impacting the filters

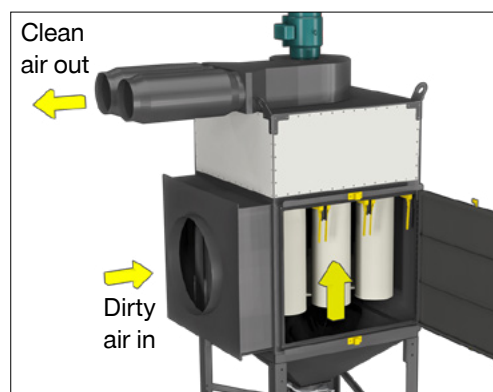

Fast and Simple Filter Replacement

- Single access, no tools required
- Clamp bars provide easy filter clamping and sealing
- No doors nor knobs to be removed



Fan Specifications

- Direct Drive/Backward Inclined blower wheel
- TEFC VFD compatible premium efficiency motor, saves energy

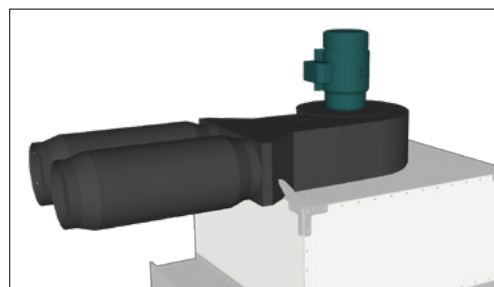

Available Options

Floor Stand & Hopper

- 54" clearance under hopper discharge flange
- Feet with bolt holes to anchor to a concrete pad

Low Profile Dust Drawer

- Reduces height by 59" from drawer to the hopper
- For low dust loading applications

Soft Start

- NEMA 12 enclosure, Magnetic SOFT START motor starter, Fuses, Thermal overload
- Step down transformer, Illuminated on/off buttons, Three position selector switch
- Integrated pulse sequencer controller board, Rotary disconnect, CSA approved

HEPA AfterFilters

- MERV 17 efficient HEPA filter captures particles at the submicron level
- Provides the highest level of filtration efficiency 99.97% at 0.3 micron
- Hot-melt separator-style glass media pack
- Actual size: 24" x 24" x 11½"
- Maximum operating temperature: 175° F / 80° C

Combustible Dust Accessories

Explosion Vents

Domed rupture disks manufactured from 304SS, 11.6 sq. ft. (1.08 sq. meters) each. Standard vent area is suitable for Class ST1 dust with a Kst value below 200 bar*m/sec. The standard vents are designed for ambient temperature conditions. The maximum operating pressure is negative 3 PSI. Consult the factory for operating conditions other than those stated.

Blowback Damper Specifications:

- 12-gauge steel construction, flange bearings, cover type access door
- Inlet and outlet bolttable ring, installed on inlet
- Ensure no re-entrainment when the blower is off
- Ensure there is a seal if a fire occurs, stopping the smoke from returning to the shop via the ductwork

Abort Damper Specifications:

- 12-gauge steel construction, electronically controlled hinged drop plate
- Used to divert & expel air back into the atmosphere as soon as there is detection of sparks or flames
- Installed on the return duct

Water-Based Fire Detection & Suppression System Specifications:

- Single Zone Control Panel, Dual High Sensitivity Infra-Red Spark Detector with flange mount
- Sense check self-test feature, spray assembly - solenoid controller water
- Spray assembly and strainer, supervised water shutoff valve
- 24 Volt DC Alarm Horn w/ 4.5 Amp backup batteries

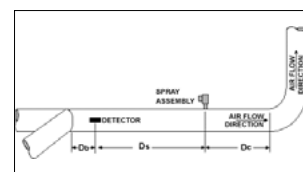
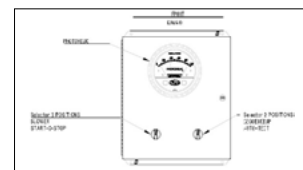

Dimensions

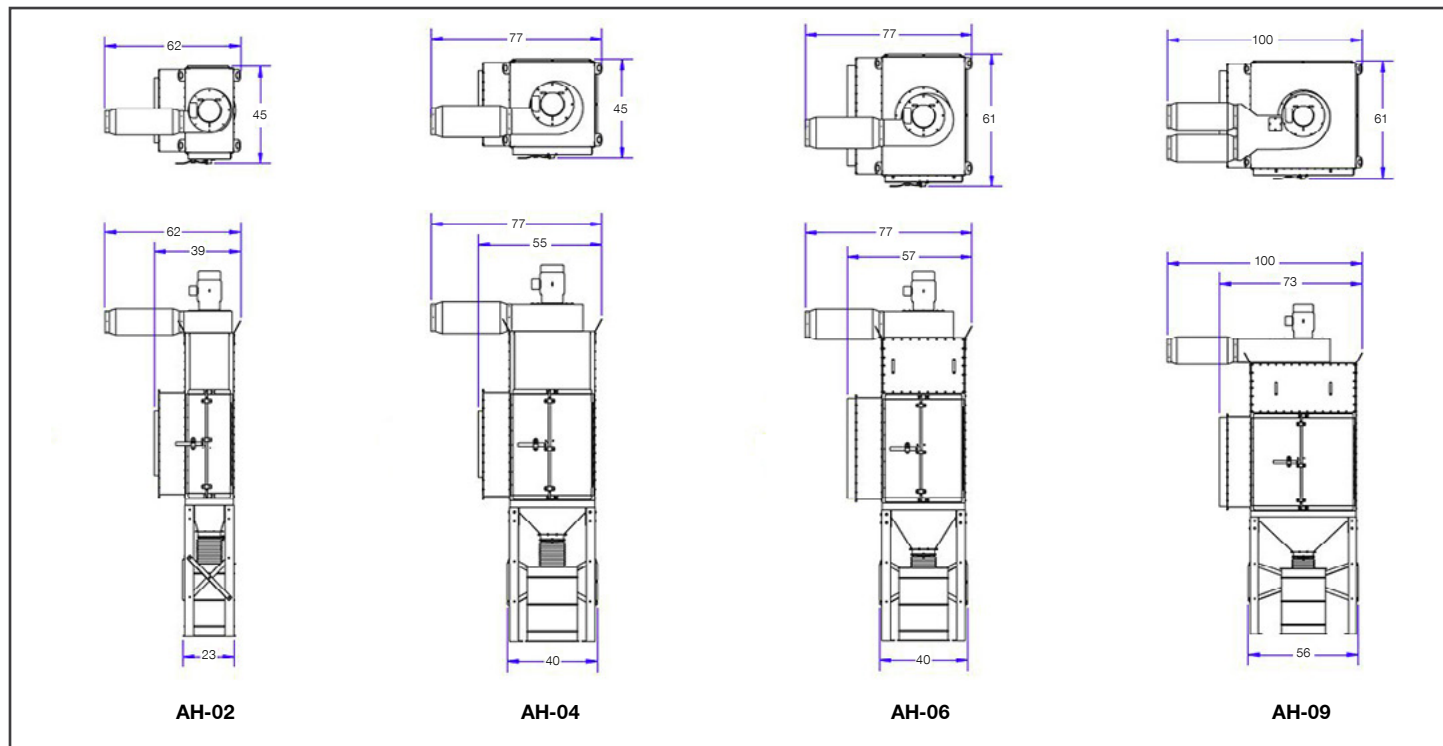

Technical Specifications

| Model | Nominal Airflow (CFM) | Motor Size | | Cartridges / Filters | | |
|------------------|-----------------------|------------|--------|----------------------|-------------|-------------------|
| | | (H.P) | (p/hz) | Qty. | Area (SQFT) | Type |
| AH-02 | 1200 | 1.5 | 1/60 | 2 | 630 | MERV 15 Nanofiber |
| | 1800 | 3.0 | 3/60 | | | |
| AH-04 | 3000 | 5.0 | 3/60 | 4 | 1280 | MERV 15 Nanofiber |
| | 4000 | 7.5 | 3/60 | | | |
| AH-06 | 4000 | 7.5 | 3/60 | 6 | 1890 | MERV 15 Nanofiber |
| | 5000 | 10.0 | 3/60 | | | |
| AH-09 | 6500 | 15.0 | 3/60 | 9 | 2835 | MERV 15 Nanofiber |
| | > 6500 | Call | Call | | | |
| AH-Custom | | | | | | |

HEAD OFFICE

2500 Alphonse Gariépy
Montreal, QC H8T 3M2

CANADA

Montreal, QC
Toronto, ON



UNITED STATES

Trenton, NJ
Chicago, IL

CONTACT US

Toll Free: 1-800-361-3733
info@diversitech.ca